



POWERED IN IRELAND BY
HONDA

Racing Car Design using Solid Edge – A Short Tutorial

In the next few minutes, students and/or teachers will model a simple racecar using Solid Edge™. With a little more practice, far more complicated race winning designs can be achieved. Here we will use Solid Edge Part to create a 3D Solid that is then ready to be manufactured! This document assumes knowledge of Microsoft Windows® and have gone through the online tutorials found under the help menu, even better if you have received training from F1 in Schools.

Copy the template file F1 In Schools to <Drive letter>:\program files\solid edge V11\templates

Step 1. Start Solid Edge, Start>programs>Solid Edge>Part. Start a new file

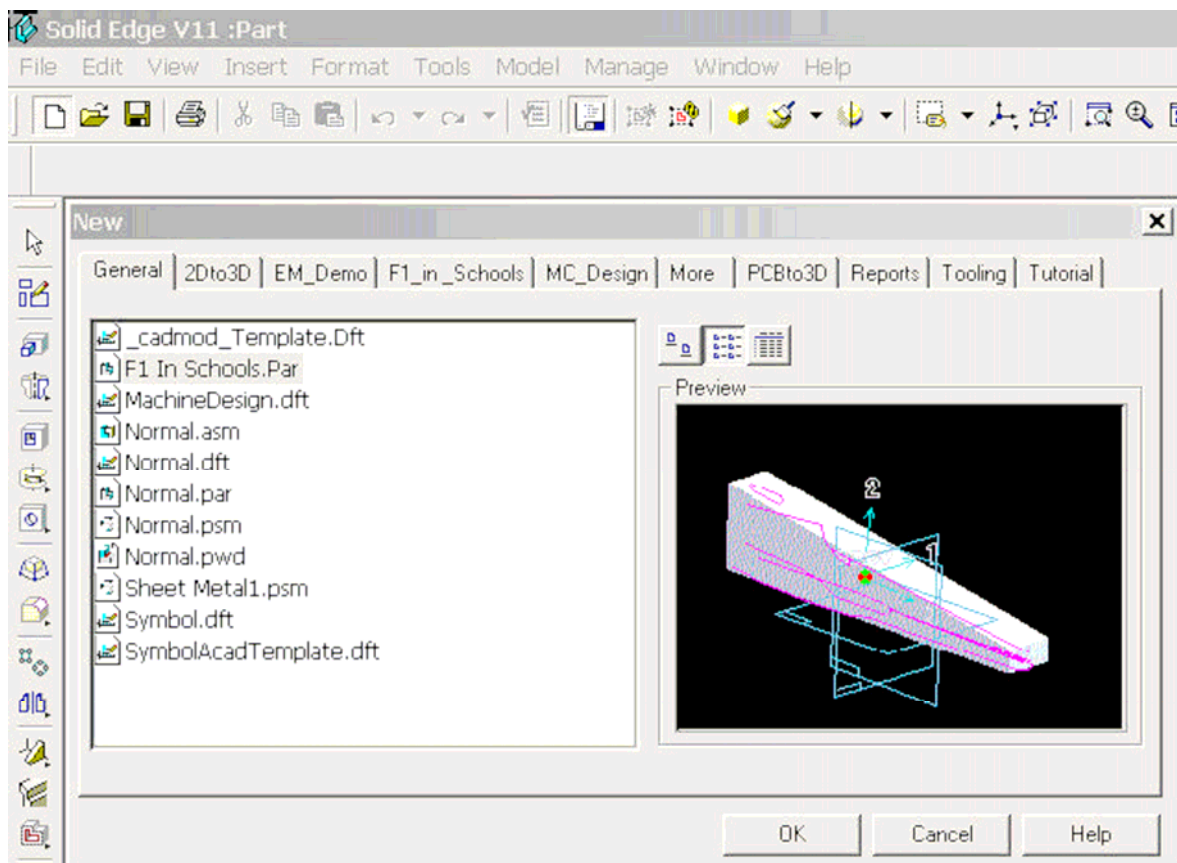

Choose F1 In Schools.par. In the new file, there is a solid in the middle, which represents the balsa wood template found in the kit. There are also a few sketches shown in purple, we will use these throughout the design to remove and add material.

Step 2. Choose the cutout command  from the left hand ribbon bar and select the 'from sketch' option on the smart step ribbon bar.

from sketch option on the smart step ribbon bar.



Select the side profile highlighted and either click the green tick on smart step or hit enter on the keyboard.

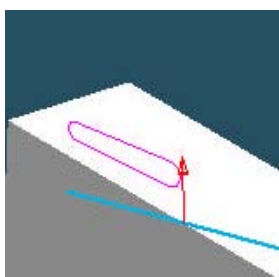
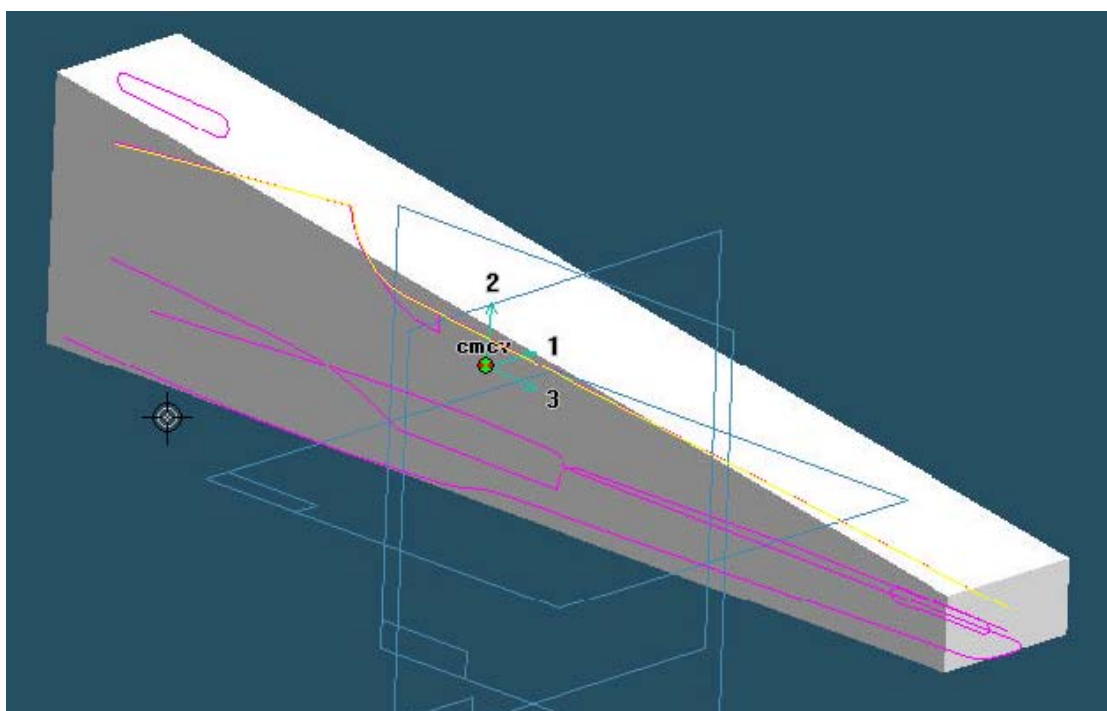

For the next step we need to show which side of the line to remove material, move the mouse cursor above the line

Choose the 'Through next' option on smart step



Move the mouse cursor over the line and when it is about half way over the line, notice the arrows change to indicate material can be removed from both sides, this is the option to choose. Material will be removed along this profile.

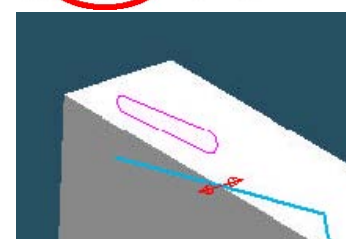

Step 3. For the next few steps we will remove material in a similar fashion. This time choose the bottom profile, again make sure the 'from sketch' option is selected in the cutout command. And remove the material as in previous step.

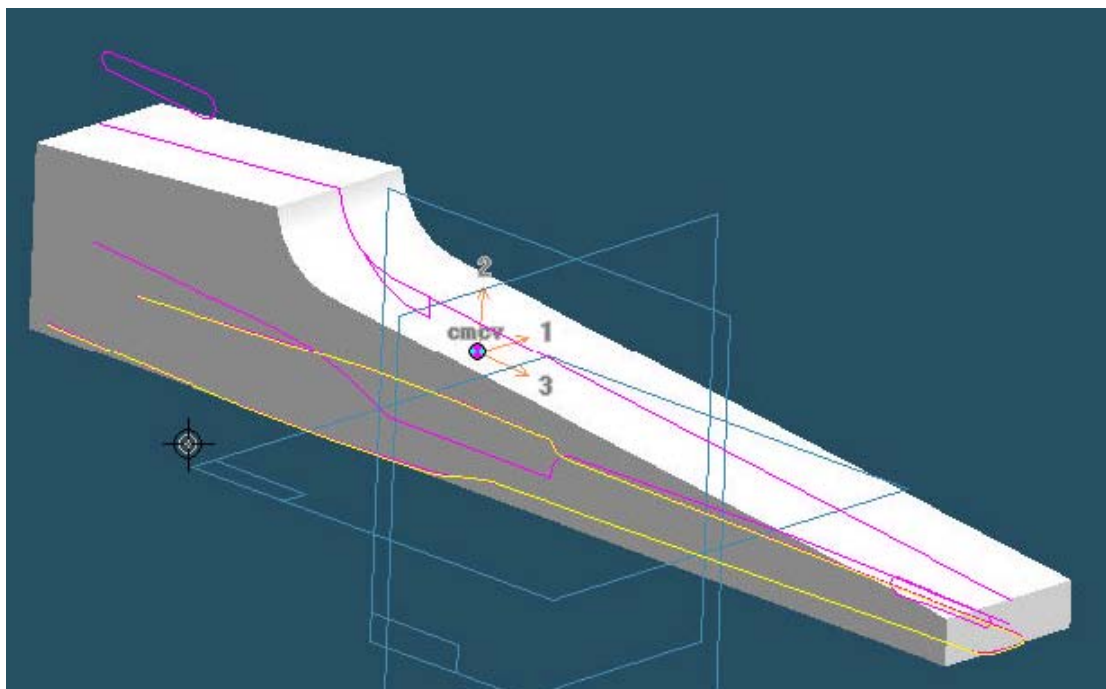

Step 4. This time choose the side profile to form the underside of the car, again make sure the 'from sketch' option is selected in the cutout command. And remove the material as in previous step.

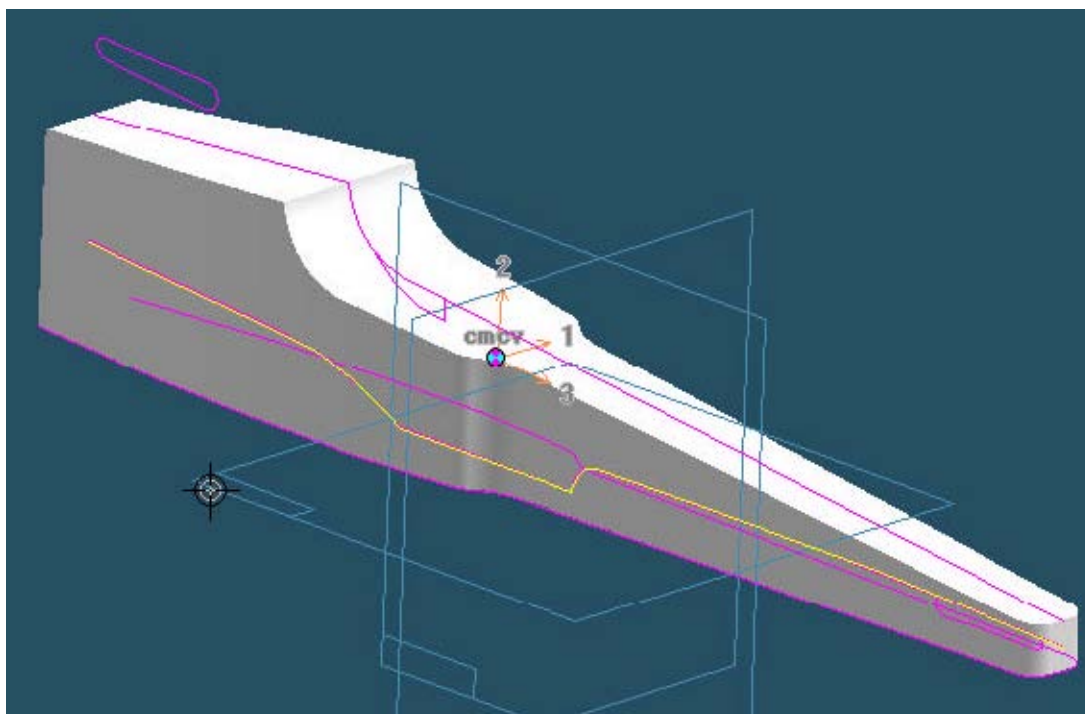

Step 5. This time choose the side profile to form cockpit, again make sure the ‘from sketch’ option is selected in the cutout command. And remove the material, but this time set the symmetrical distance to 20mm.

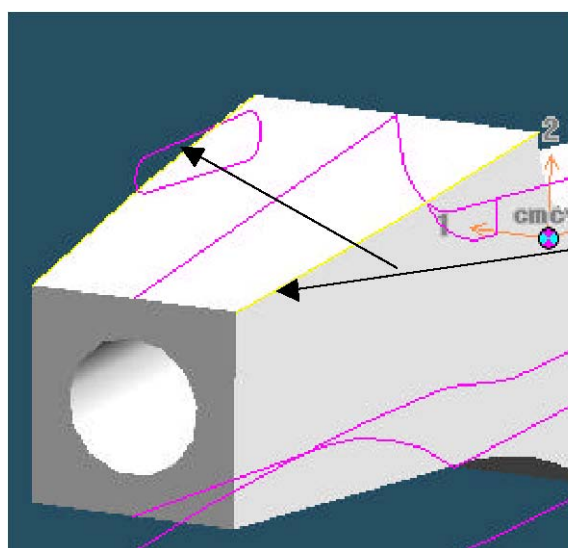
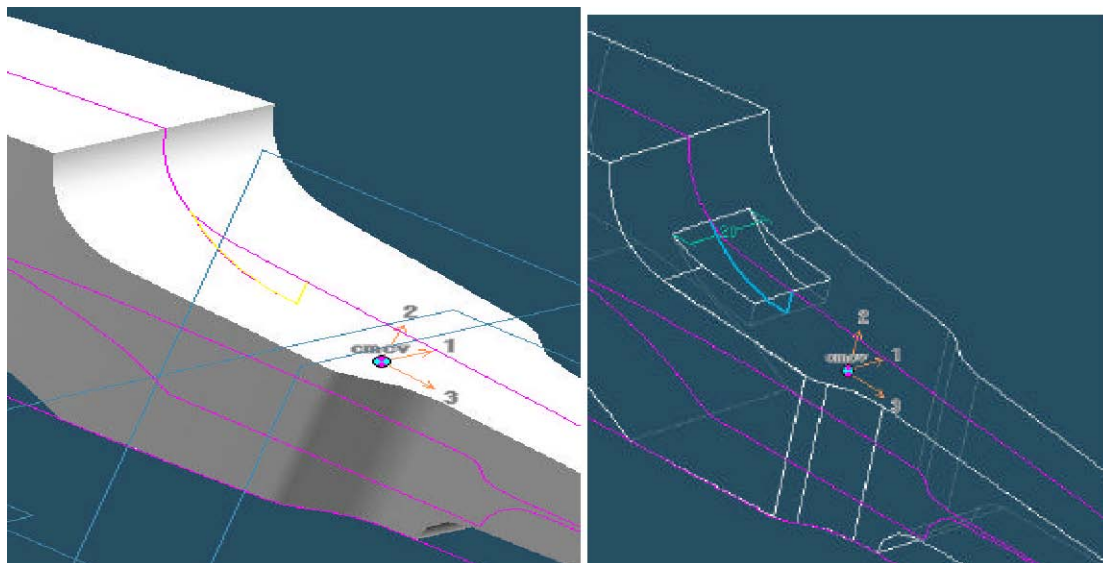

Step 6. So now we have the basic shape of the car, we will add some rounds to help streamline our racer.

Choose the round command  and select the two top edges shown, make the radius 15mm.

Step 7. The next round we will do is a little more complicated. Spin the model over 180 deg.

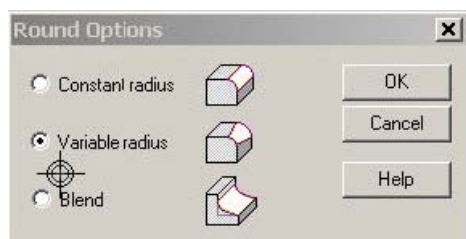

Choose the variable round option and select the edge shown.

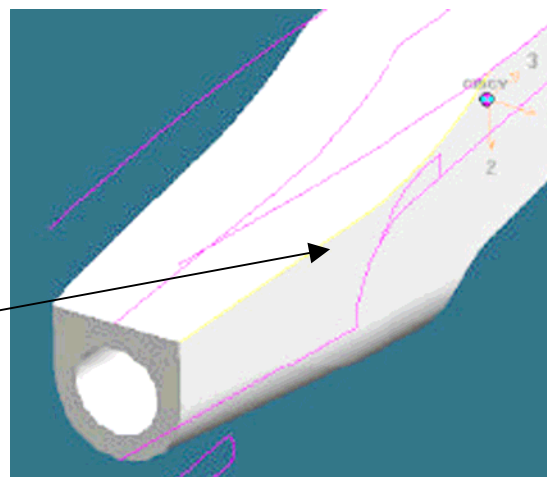

On the back end of the line click and make the value 15mm. And the front edge round 6mm.

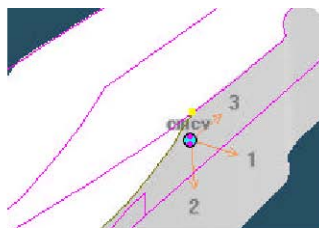
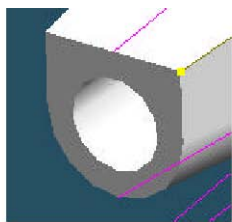

The finished result is on the right. Repeat on the other side.

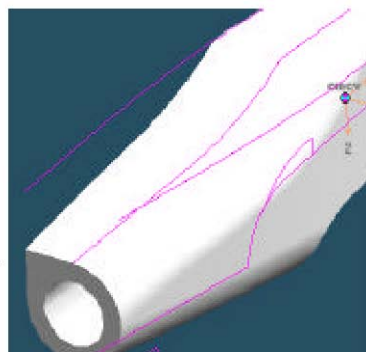

Step 8. Round the front of the chassis with a variable blend, starting at 3mm on the nose up to 6mm round the back of the cockpit.

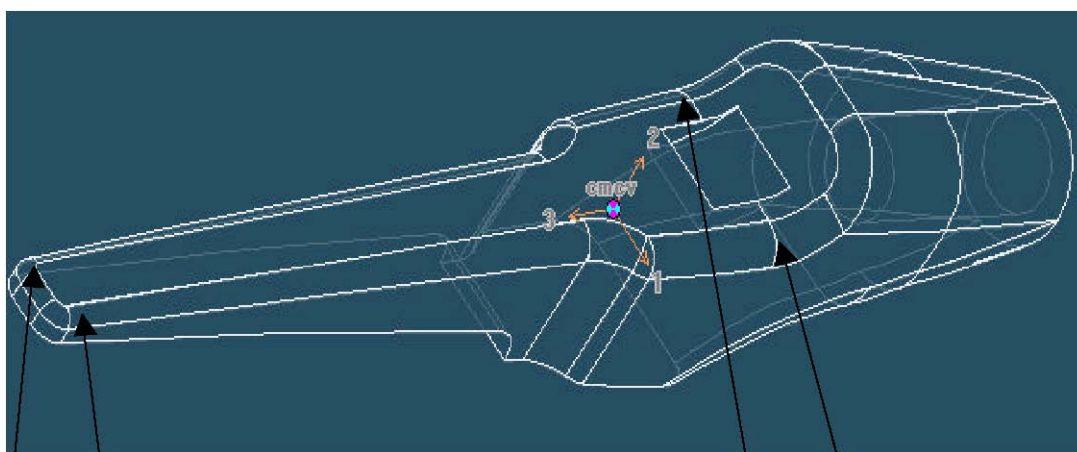

3mm Rad

6mm Rad

Step 9. Round the cockpit, round the front edges 10mm, and the side's 2mm, this should be done in 2 stages, firstly the bottom of the cutout and then the top perimeter.

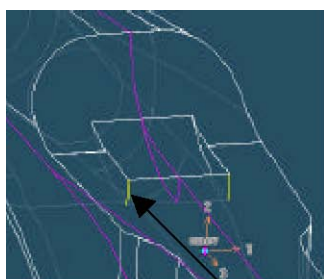

10mm Rad

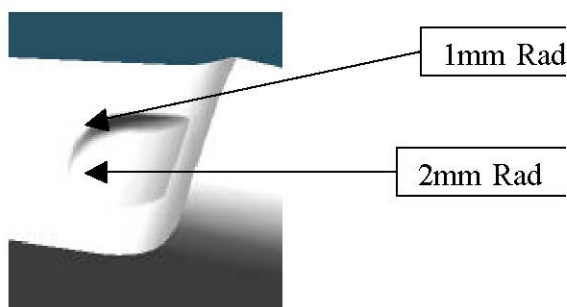

Step 10. Round the underside of the car using dimensions shown

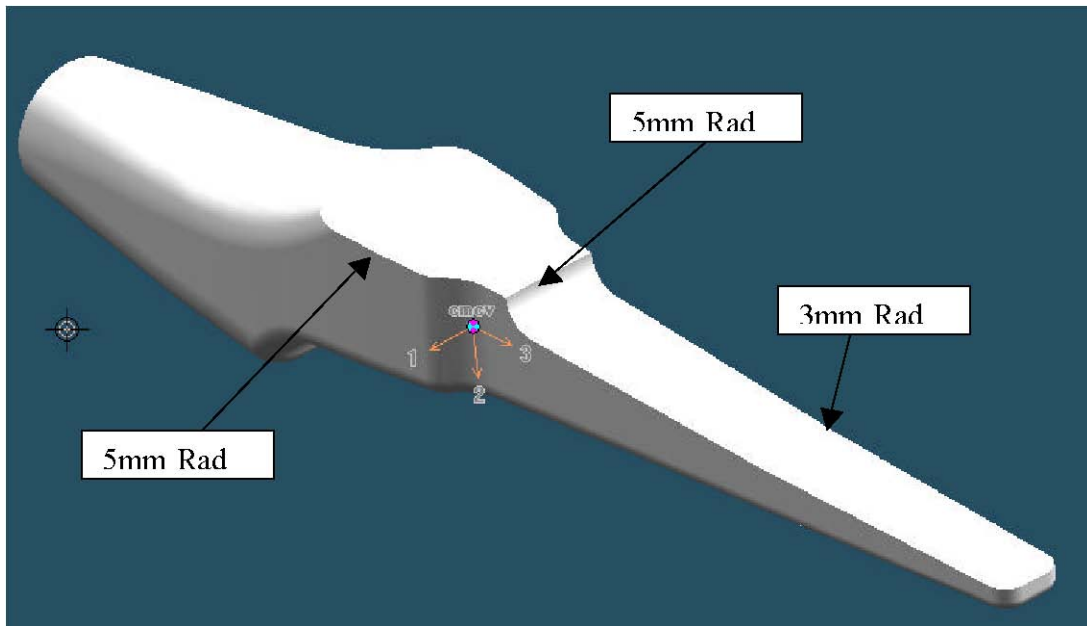

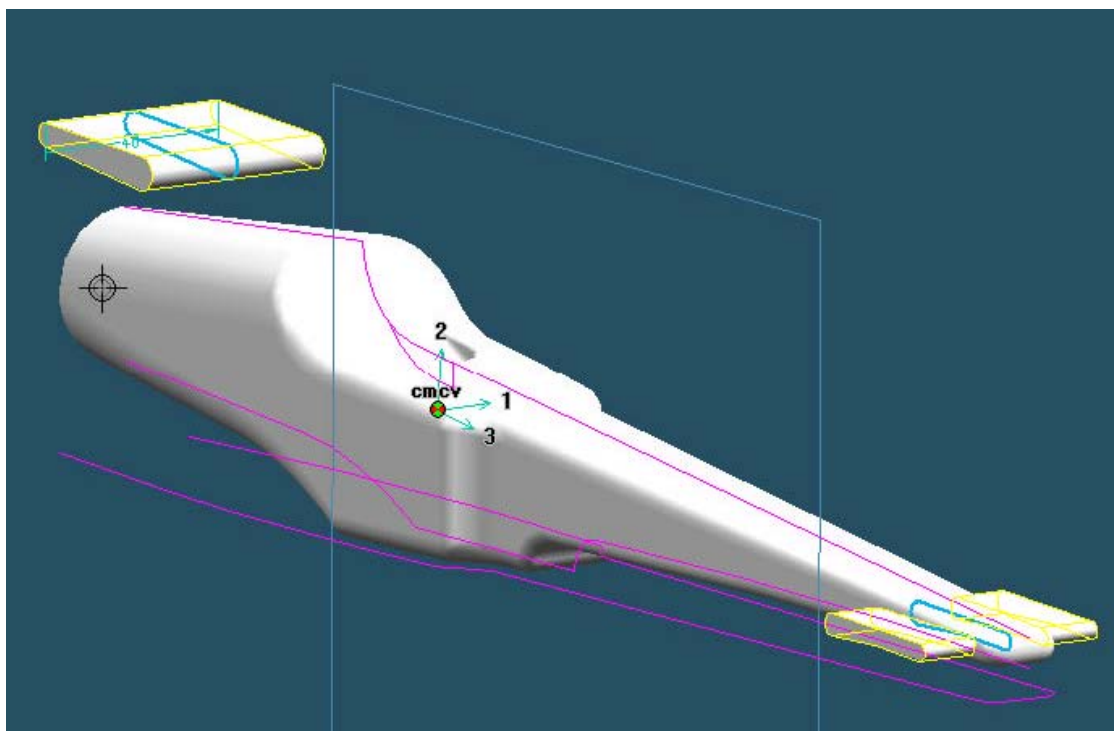

Step 11. Now we will add some aerofoil to help with down force. Select the protrusion command  and again make sure the 'by sketch' option is selected and choose the profiles show and make the symmetrical to a dimension of 40mm.

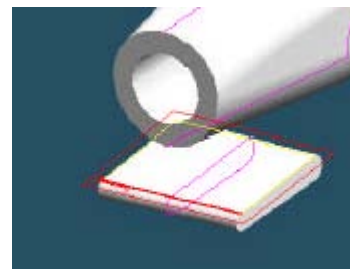

Step 12. To connect the rear aerofoil to the car body, we need to create a small spar using the protrusion to add material. In order to get the spar in the right place, spin the car over until it is upside-down as shown and choose the underside of the aerofoil, choose the left hand side if the plane to orient the view and click on the left hand side of the line, you will now be looking at the view in plan. (Note: in V12 the steps to orient the view are no longer necessary).



Next we will draw the profile. Use the include command  to include the 2 lines shown to create a 'V'. Draw and Arc  at the top as shown, and then using the fillet tool fillet the lower corner 0.5mm, And then trim  the top lines back to the initial arc.

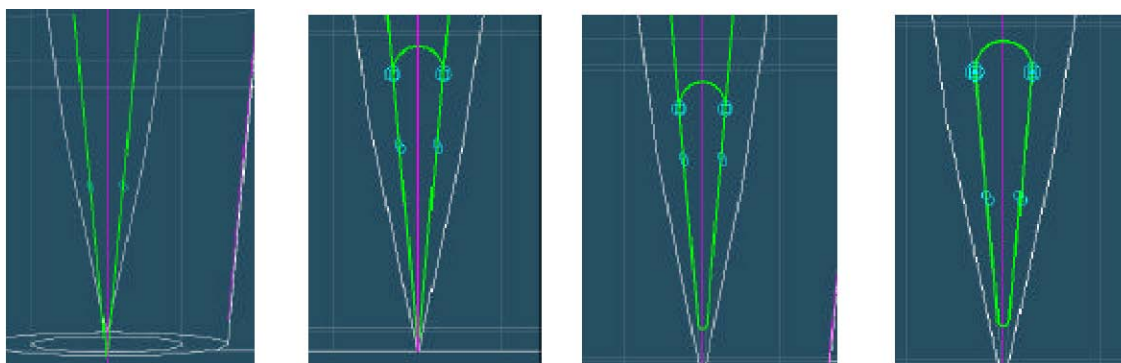

Using the 'to next'  Option send the protrusion up to the next surface.

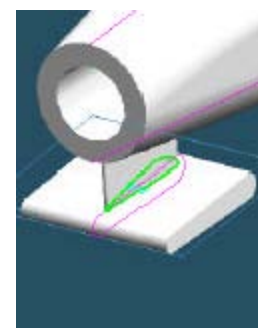

Step 13. Round all the edges of the aerofoils for extra streamlining!

Step 14. Wheel Mounts. Create a protrusion from plan 3 and sketch a profile as shown. Send the profile to the inside & Make the profile symmetrical and 5mm thick.

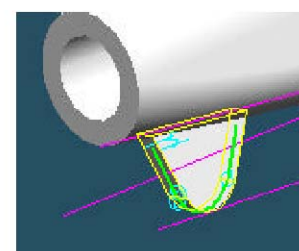
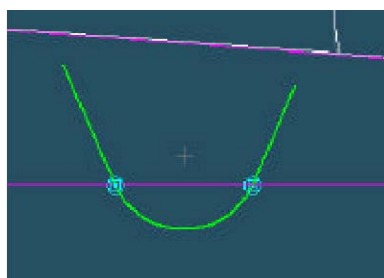

Step 15: Repeat for the front axle and add 2 –off 3mm mounting holes. The profile of the car should now look like the example below

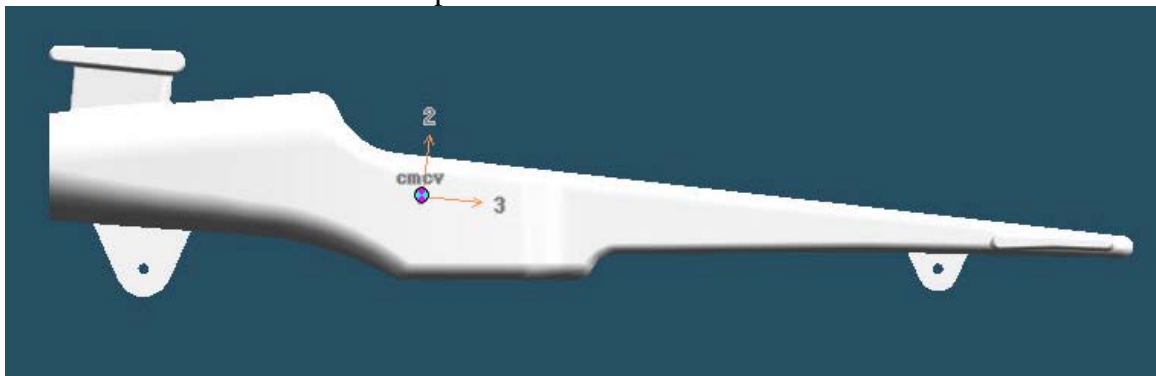

This concludes the modelling of the racecar. It is now ready to be passed to the CNC software, and be manufacture.

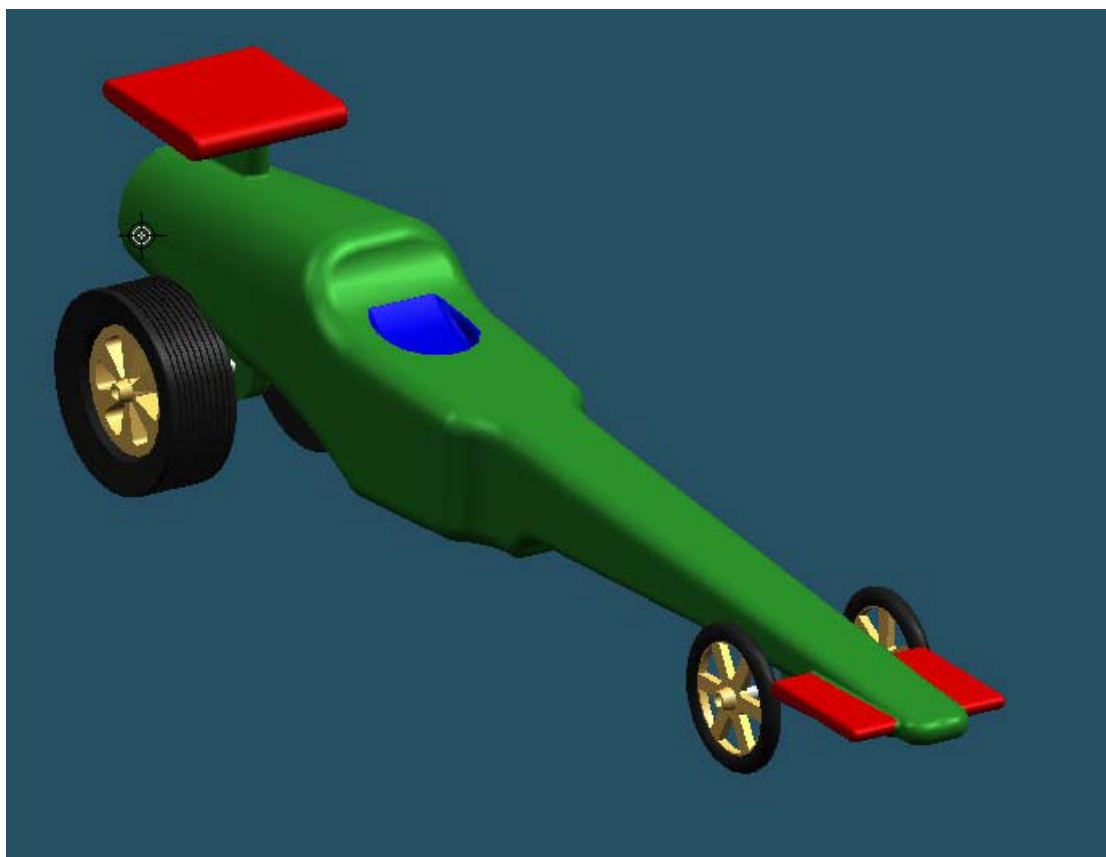

Good luck with the competition!